

Code: BCS-DMIP1130A

IP CAMERA **BCS-DMIP1130A** - 1.3 Mpx 2.8 mm

Net: **89.18 EUR** Gross: **89.18 EUR**

IP camera equipped with very good high resolution sensor. Due to above it is perfect solution for surveillance systems requiring persons or vehicles recognition.

Very easy operation by Internet Explorer browser allows the users to convenient and remote support, and also remote management of the camera. Included camera software enables management and integrated monitoring of many network cameras.



SPECIFICATION

Standard:	TCP/IP
Sensor:	1/3 " Progressive Scan Aptina CMOS
Digital Image Processor:	DSP AMBARELLA
Matrix size:	1.3 Mpx
Scanning system:	Progressive
Resolution:	<ul style="list-style-type: none">• 1280 x 960 - 1.3 Mpx,• 1280 x 720 - 720p,• 704 x 576 - D1,• 352 x 288 - CIF
Lens:	2.8 mm
View angle:	81 ° (manufacturer data) 83 ° (our tests result)
Min. illumination:	0.1 Lux (color) 0.01 Lux (B/W)
S/N ratio:	> 50 dB
RS-485 interface:	—
Memory card slot:	32 GB microSD HC (High Capacity)
Image compression method:	H.264 / MJPEG
Alarm inputs / outputs:	—
Audio:	—
Bitrate:	32 ... 8192 kbps - H.264 32 ... 12288 kbps - MJPEG
Main stream frame rate:	25 fps - 1.3 Mpx
Network interface:	10/100 Base-T (RJ-45)
Network protocols:	HTTP, HTTPS, TCP/IP, RTSP, RTP, UDP, RTCP, SMTP, FTP, DHCP, DNS, DDNS, PPPOE, UPNP, NTP

Mobile phones support:	Port no.: 37777 or access by a cloud (P2P) <ul style="list-style-type: none"> • Android: Free application DMSS • iOS (iPhone): Free application DMSS • Windows Phone: Free application wDMSS Lite There are also paid versions of mobile applications: gDMSS Plus, iDMSS Plus, wDMSS plus
WEB Server:	Built-in, NVR compliance
Max. number of on-line users:	10
ONVIF:	2.0
Main features:	<ul style="list-style-type: none"> • ICR - Movable InfraRed filter • WDR - Wide Dynamic Range • 3D-DNR - Digital Noise Reduction • BLC/HLC - Back Light / High Light Compensation • Mirror - Mirror image • Motion Detection • Configurable Privacy Zones • Sharpness - sharper image outlines
Vandal-proof:	✓
Power supply:	<ul style="list-style-type: none"> • PoE (802.3af), • 12 V DC / 140 mA
Housing:	Dome - Metal
Color:	White
Operation temp:	-20 °C ... 50 °C
"Index of Protection":	IP66
Weight:	0.26 kg
Dimensions:	Ø 110 x 54 mm
Supported languages:	English, Polish
Manufacturer / Brand:	BCS
Guarantee:	2 years

PRESENTATION

Camera view after remove the Dome cover:



Mounting side view:



Dimensions:

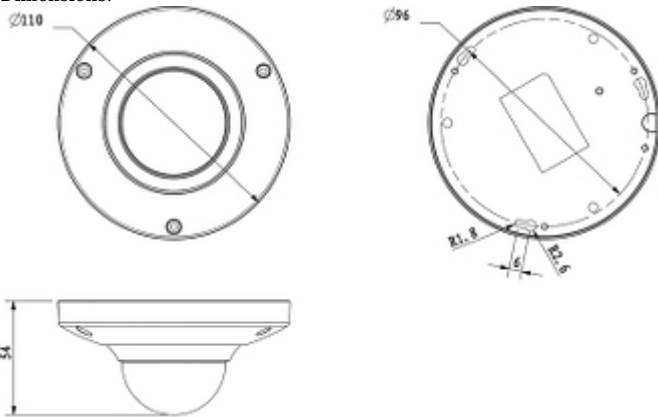

In the kit:



OUR TESTS

Camera image at artificial illumination (about 30Lux):



Camera image at direct strong light opposite to camera:



Camera image at night conditions, at different illumination values show below:

1 LUX:



0.1 LUX:



0.01 LUX:

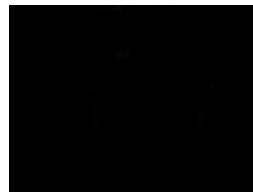

PACKAGE

Dimensions (L x W x H): 0x0x0 mm	Gross Weight: 0 kg
----------------------------------	--------------------



DELTA-OPTI Monika Matysiak; <https://www.delta.poznan.pl>
POL; 60-713 Poznań; Graniczna 10
e-mail: delta-opti@delta.poznan.pl; tel: +(48) 61 864 69 60