

Code: BCS-DMIP1130

## IP CAMERA **BCS-DMIP1130** - 960p 2.8 mm

Net: **110.39 EUR** Gross: **110.39 EUR**

IP camera equipped with very good high resolution sensor. Due to above it is perfect solution for surveillance systems requiring persons or vehicles recognition. The camera has a very flat profile, it's only 54 mm out from the ceiling.

Very easy operation by Internet Explorer browser allows the users to convenient and remote support, and also remote management of the camera. Included camera software enables management and integrated monitoring of many network cameras.



### SPECIFICATION

Standard:	TCP/IP
Sensor:	1/3 " Progressive Scan Exmor CMOS
Matrix size:	1.3 Mpx
Scanning system:	Progressive
Resolution:	<ul style="list-style-type: none"><li>• 1280 x 960 - 960p,</li><li>• 1280 x 720 - 720p,</li><li>• 704 x 576 - D1,</li><li>• 352 x 288 - CIF</li></ul>
Lens:	2.8 mm
View angle:	81 °
Min. illumination:	0.1 Lux (color) 0.05 Lux (B/W)
S/N ratio:	> 50 dB
RS-485 interface:	—
Memory card slot:	—
Compression:	H.264 / MJPEG
Alarm inputs / outputs:	—
Audio:	—
Bitrate:	32 ... 8192 kbps - H.264 32 ... 12288 kbps - MJPEG
Main stream frame rate:	15 fps - 1.3 Mpx 25 fps - 720p
Network interface:	10/100 Base-T (RJ-45)
Network protocols:	IPv4/IPv6, HTTP, HTTPS, SSL, TCP/IP, UDP, UPnP, ICMP, IGMP, SNMP, RTSP, RTP, SMTP, NTP, DHCP, DNS, PPPOE, DDNS, FTP, IP Filter, QoS, Bonjour
WEB Server:	Built-in, NVR compliance
Max. number of on-line users:	10
ONVIF:	2.0
Mobile phones support:	Android, iOS (iPhone, iPad), Windows Phone

Main features:	<ul style="list-style-type: none"> <li>• Motion Detection</li> <li>• DNR - Digital Noise Reduction</li> <li>• Configurable Privacy Zones</li> <li>• Sharpness - sharper image outlines</li> <li>• Mirror - Mirror image</li> <li>• AGC - Automatic Gain Control</li> <li>• Day/Night mode (color/b&amp;w/auto)</li> </ul>
Power supply:	<ul style="list-style-type: none"> <li>• PoE (802.3af),</li> <li>• 12 V DC / 150 mA</li> </ul>
Housing:	Metal
Color:	White
Vandal-proof:	✓
Operation temp:	-20 °C ... 50 °C
"Index of Protection":	IP66
Weight:	0.26 kg
Dimensions:	Ø 110 x 54 mm
Supported languages:	English
Manufacturer / Brand:	BCS
Guarantee:	2 years

## PRESENTATION

Camera view after remove the Dome cover:



Mounting side view:



Dimensions:

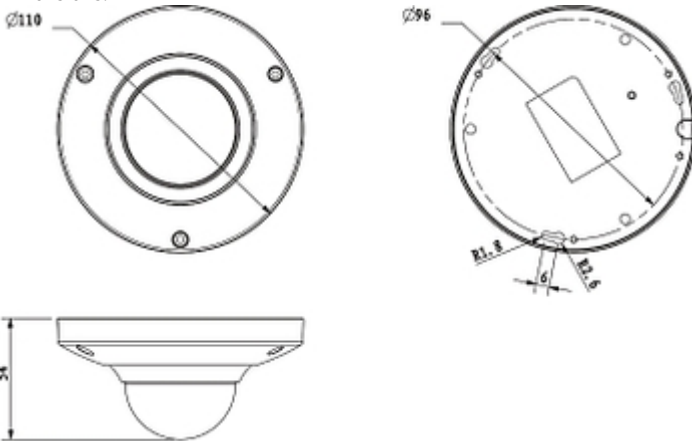

In the kit:

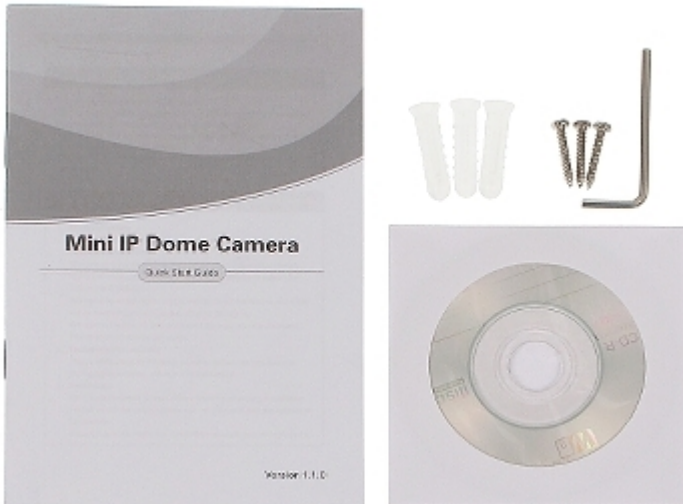

## PACKAGE

Dimensions (L x W x H): 0x0x0 mm	Gross Weight: 0 kg
----------------------------------	--------------------



DELTA-OPTI Monika Matysiak; <https://www.delta.poznan.pl>  
POL; 60-713 Poznań; Graniczna 10  
e-mail: [delta-opti@delta.poznan.pl](mailto:delta-opti@delta.poznan.pl); tel: +(48) 61 864 69 60