

Code: OMP-50W50

WALL BRACKET **OMP-50W50**

Net: **33.63 CHF** Gross: **33.63 CHF**

Wall bracket allows to mount the antenna masts to the wall.
The kit includes two elements.



SPECIFICATION

Material:	Metal
Mast diameter:	max. 50 mm
Distance from tube to the wall:	500 mm
Mount:	10 x Expansion plugs Ø 12 mm
Main features:	<ul style="list-style-type: none">• The whole galvanized• It has support
Manufacturer / Brand:	DELTA
Guarantee:	3 years

PRESENTATION

DELTA-OPTI Monika Matysiak; <https://www.delta.poznan.pl>
POL; 60-713 Poznań; Graniczna 10
e-mail: delta-opti@delta.poznan.pl; tel: +(48) 61 864 69 60

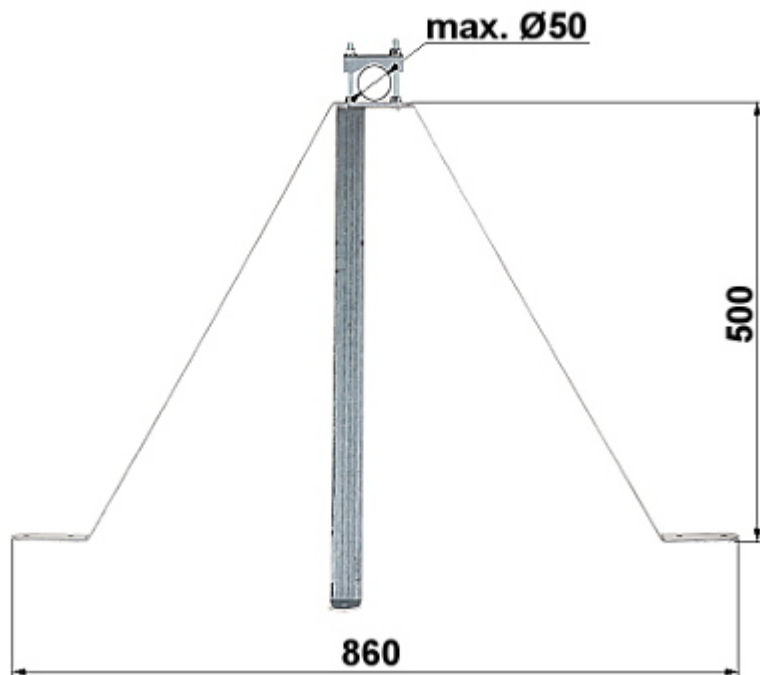

In the kit:



PACKAGE

Dimensions (L x W x H): 0x0x0 mm	Gross Weight: 0 kg
----------------------------------	--------------------