

Code: DS-2CD1743G2-LIZU(2.8-12MM)

# IP VANDALPROOF CAMERA **DS-2CD1743G2-LIZU(2.8-12MM)** Smart Hybrid Light - 3.7 Mpx Hikvision

Net: **308.74 EUR** Gross: **308.74 EUR**

IP camera with efficient H.265 / H.264 image compression algorithm for clear and smooth video streaming at maximal resolution of 4 MPx. Due to above it is perfect solution for surveillance systems requiring persons or vehicles recognition. The used motozoom lens with 2.8 ... 12 mm focal length allows to remote view angle adjustment.

PoE powering possibility, compatible with the 802.3af standard makes the device more universal and easier to install.

**Attention!** The device is equipped with Smart Hybrid Light technology, thanks to which the user has a choice of white light mode and IR (infrared) mode. When Smart Hybrid Light is active, the white light will turn on automatically only when an object is detected in the monitored area, which effectively improves the image quality.



## SPECIFICATION

Standard:	IP
Resolution:	2560 x 1440 - 3.7 Mpx , 1920 x 1080 - 1080p 1280 x 720 - 720p
Sensor:	1/3 " Progressive Scan CMOS
Lens:	2.8 ... 12 mm - Motozoom
View angle:	97 ° ... 30 °
Range of IR illumination:	30 m
White light LED illuminator range:	30 m
RS-485 interface:	—
Memory card slot:	Micro SD card support up to 512GB
Image compression method:	H.265+ / H.265 / H.264+ / H.264 / MJPEG
Alarm inputs / outputs:	—
Audio:	<ul style="list-style-type: none"><li>• Microphone built-in</li><li>• Audio transmission via network</li><li>• Noise and echo reduction</li><li>• Compliance with the AAC standard</li></ul>
Network interface:	10/100 Base-T (RJ-45)
WEB Server:	Built-in, Web Viewer
Max. number of on-line users:	6
ONVIF:	✓



DELTA-OPTI Monika Matysiak; <https://www.delta.poznan.pl>  
POL; 60-713 Poznań; Graniczna 10  
e-mail: [delta-opti@delta.poznan.pl](mailto:delta-opti@delta.poznan.pl); tel: +(48) 61 864 69 60

Main stream frame rate:	<ul style="list-style-type: none"> <li>• 20 fps @ 4 Mpx</li> <li>• 25 fps @ 1080p</li> </ul>
Mobile phones support:	Port no.: 8000 or access by a cloud (P2P) <ul style="list-style-type: none"> <li>• Android: Free application <a href="#">Hik-Connect</a></li> <li>• iOS: Free application <a href="#">Hik-Connect</a></li> </ul>
Default IP address:	192.168.1.64
Default admin user / password:	admin / - The administrator password should be set at the first start
Web browser access ports:	80
PC client access ports:	Port no.: 8000 or access by a cloud (P2P) - iVMS-4200 application
Mobile client access ports:	8000
Port ONVIF:	80
RTSP URL:	<ul style="list-style-type: none"> <li>• Main stream : rtsp://user:password@192.168.1.64:554/Streaming/Channels/101/ - with authorization</li> <li>• Sub stream : rtsp://user:password@192.168.1.64:554/Streaming/Channels/102/ - with authorization</li> </ul>
Main features:	<ul style="list-style-type: none"> <li>• Smart Hybrid Light technology - IR or LED illuminator works in night mode. White light will turn on automatically only when an object is detected in the monitored area, which effectively improves image quality</li> <li>• Motozoom lens</li> <li>• WDR - 120 dB - Wide Dynamic Range</li> <li>• 3D-DNR - Digital Noise Reduction</li> <li>• ROI - improve the quality of selected parts of image</li> <li>• IP addresses filtering</li> <li>• Auto White Balance</li> <li>• BLC - configurable Back Light Compensation</li> <li>• ICR - Movable InfraRed filter</li> <li>• Smart motion detection (with recognizing people and vehicles)</li> <li>• Configurable Privacy Zones</li> <li>• Mirror - Mirror image</li> <li>• Sharpness - sharper image outlines</li> <li>• RESET button</li> </ul>
Power supply:	<ul style="list-style-type: none"> <li>• PoE (802.3af),</li> <li>• 12 V DC / 800 mA</li> </ul>
Power consumption:	<ul style="list-style-type: none"> <li>• ≤ 12 W @ PoE (802.3af/at)</li> <li>• ≤ 9.6 W @ 12 V DC</li> </ul>
Housing:	Dome - Metal
Color:	White
Mechanical protection class:	IK08
"Index of Protection":	IP67
Operation temp:	-30 °C ... 60 °C
Weight:	0.5 kg
Dimensions:	Ø 120 x 90 mm
Supported languages:	English, Ukrainian
Manufacturer / Brand:	Hikvision
SAP Code:	311325240
Guarantee:	2 years

## PRESENTATION

Camera view after remove the Dome cover:



DELTA-OPTI Monika Matysiak; <https://www.delta.poznan.pl>  
 POL; 60-713 Poznań; Graniczna 10  
 e-mail: [delta-opti@delta.poznan.pl](mailto:delta-opti@delta.poznan.pl); tel: +(48) 61 864 69 60



Memory card slot and "Reset" button:



Mounting side view:

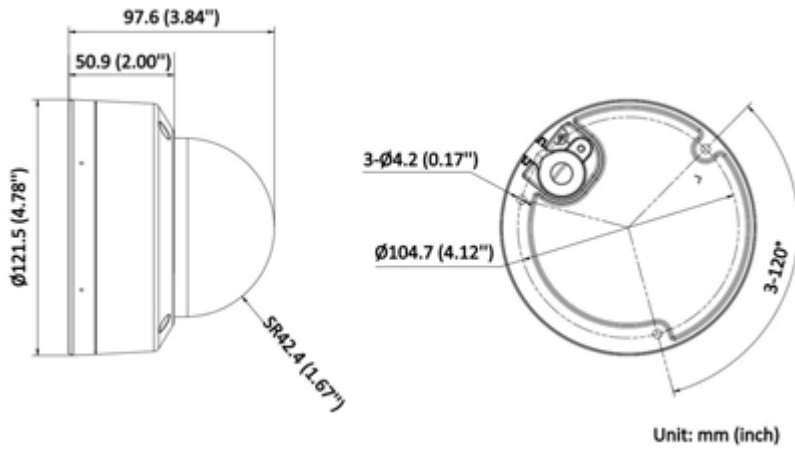

In the kit:



**PACKAGE**

Dimensions (L x W x H): 0x0x0 mm	Gross Weight: 0 kg
----------------------------------	--------------------

